



There is a **Nonrefundable \$1,200.00** application fee for review of this application.

Montana Rail Link, Inc. ("MRL") utilizes the BNSF Railway Company ("BNSF") Utility Accommodation Policy ("UAP") for design and construction standards for proposed encroachments of utility facilities. Please consult the UAP for such standards prior to submission of this application.

The UAP is updated periodically and is available here: <https://www.bnsf.com/bnsf-resources/pdf/about-bnsf/utility.pdf>

Please be aware that MRL, upon review of this application, may require additional conditions not specified in the UAP for any proposed utility installation or modification work specified herein.

MRL reserves the right to: 1) require applicant to contact any affected parties (ex: MRL lessees, roadway authorities, utility companies) in the area of a proposed utility encroachment; and 2) require applicant to verify, in writing, all affected parties' pre-approval of any proposed installation, as part of the application review process.

PIPELINE INFORMATION:

All applicants must show the labeled Zone A and Zone B excavation lines from the "General Excavation Zones" drawing found in the file attached to this application form (attached/linked [here](#)), on all cross-section drawings for pipeline crossings. Applications cannot be processed without this information shown on the cross-sections.

MRL Shoring Specifications: Project plans must include notes to the Contractor requiring the Contractor to meet Montana Rail Link, Inc. ("MRL")'s Shoring Specifications found in the attached/linked PDF [file](#), for all pipeline crossings. The project plans or specifications **must** include the entire MRL Shoring Specifications verbatim if the casing pipe terminates within Zone A or Zone B of the General Excavation Zones.

Agreement Holder Information:

Name of Agreement Holder:	Phone No:
Email Address:	Contact Name & Phone No:
Corporation (if any):	State in which incorporated:
Complete Business Address (if different from below):	
Complete Billing Address & Phone Number:	
If not a corporation, name(s) of owners or partners:	
Applicant Reference No (if any):	

Pipeline Product Information:

Application For (choose one): Pipeline Crossing Pipeline parallel to track Both

Application Type (choose one): New Installation Existing (Repair or Upgrade) Both

If application corresponds to an existing wireline, specify existing railroad agreement/permit number(s):

Product to be handled in pipeline: _____

(Example: Potable Water, Sanitary Sewer, Sewer Effluent, Natural Gas, Liquid Petroleum, etc.)

Location Information:

Name of nearest city or town: <i>(Example: Missoula, etc.)</i>	County: <i>(Example: Missoula, etc.)</i>	State: Montana
Distance and direction from nearest Railroad milepost: <i>(Example: 2,500' west of milepost 25 on the 9th subdivision (See GIS Map))</i>		
Quarter Section, Section, Township, Range:		
Distance in feet measured along the track from the point pipe crosses the track (main track or more than one track) to known point on Railroad (centerline of road crossing, center of railroad culvert, east or west end of a railroad bridge, points of a railroad switch): <i>(Example: 2,500' east of 3rd Avenue road crossing, Twin Bridges on the 7th subdivision – see GIS map)</i>		
If a transfer of an existing Agreement, please provide current Agreement No.: <i>(Example: 250100, etc.)</i>		
Angle pipe will make with track at the point of crossing: <i>(Example: 38°, 88°, etc.)</i>		
Distance from centerline of nearest track if a parallel pipeline encroachment: <i>(Example: 138', 200', etc.)</i>		
Is crossing within a public road right of way? <input type="radio"/> Yes <input type="radio"/> No If Yes: Name of road: _____ Road Right of way width _____ feet		
US Dept. of Transportation Railroad Crossing No.: <i>(Will be a six-digit number ending with a letter - example: 091662K)</i> Federal Railroad Administration (FRA) Safety Map can be used to identify crossing: fragis.fra.dot.gov/GISFRASafety/		
Total length of pipeline on railroad right of way: <i>(Example: 138', 200', etc.)</i>		

Carrier Pipe Information:

Inside Diameter: <i>(Example: 10", 36", etc.)</i>	Wall Thickness: <i>(Example: .25", .80", etc.)</i>
Pipe material: <i>(Example: HDPE, PVC, Ductile Iron, etc. (See UAP for requirements))</i>	Material specification(s): <i>(Example: SCH 40, SDR-11, C900 etc. (See UAP for requirements))</i>
Working pressure: _____ Psi <i>(Example: 60, 100 (See UAP for requirements))</i>	
Cathodic protection provided? <input type="radio"/> Yes <input type="radio"/> No	Coating: <i>Yes or No, Specify type(See UAP for requirements)</i>

Casing Pipe Information:

Inside diameter:	Wall thickness:
Pipe material: <i>(Example: Steel, HDPE, Cast Iron, etc. (See UAP for requirements))</i>	Material specification: <i>(Example: SCH 80, SDR-11, SDR-9, etc. (See UAP for requirements))</i>
Length of casing: <i>(Example: 138', 200', etc.)</i>	Number of vents: <i>(Example: 1, 2 etc.)</i>
Cathodic protection provided? <input type="radio"/> Yes <input type="radio"/> No	Coating: <i>Yes or No, Specify Abrasion resistant (See UAP for requirements)</i>

Construction Information:

Method of installation (choose one): <input type="radio"/> Dry Boring <input type="radio"/> Jacking <input type="radio"/> Trenching (for longitudinal installation only) <input type="radio"/> Other _____
Distance from header of dry boring or jacking pit to center of closest track measured perpendicular to track: <i>(Example: 138', 200' etc.)</i>
Vertical distance from base of rail of lowest track to top of casing: <i>(Example: 12', 35' (See UAP for requirements))</i>
Distance from bottom of track ditch to top of pipe: <i>(Example: 6', 12' (See UAP for requirements))</i>
Distance below ground surface outside of track and track ditch area: <i>(Example: 6', 12' (See UAP for requirements))</i>

MRL requires the submission of the following items along with this form for the application to be processed for Engineering Department review:

- 1) Two copies of this application;
- 2) Plan view and cross-sectional view sketches showing the proposed wireline and the railroad track for total occupancy of railroad property, including actual designed depths, heights, and distances, not minimum standards. **Please refer to the BNSF UAP for requirements for plans sealed by a Professional Engineer, prior to submitting plans.**
- 3) A planimetric CAD file, which shall be in the Montana State Plane coordinate system, in ground distances, and AutoCAD .dwg file format; and
- 4) Payment of the non-refundable application fee specified above.

If in the opinion of Railroad, sufficient hazard is involved, Railroad will supply a flagman, with proper advance notice, or if the wireline installation requires removal, replacement, modification, or locating of track, bridges, signals, railroad wires or pipelines, roads, or the supply of railroad engineering or supervision, the applicant agrees the full cost of such railroad services will be borne by the applicant.

Failure to provide all of the requested information will result in the automatic cancellation of this application.

Signature of Applicant _____
Title

Date

If a consultant or other third party is preparing this application, please fill out the below information:

Name of individual preparing application: _____

Name of firm: _____

Business Address of preparer: _____

Telephone Number: _____

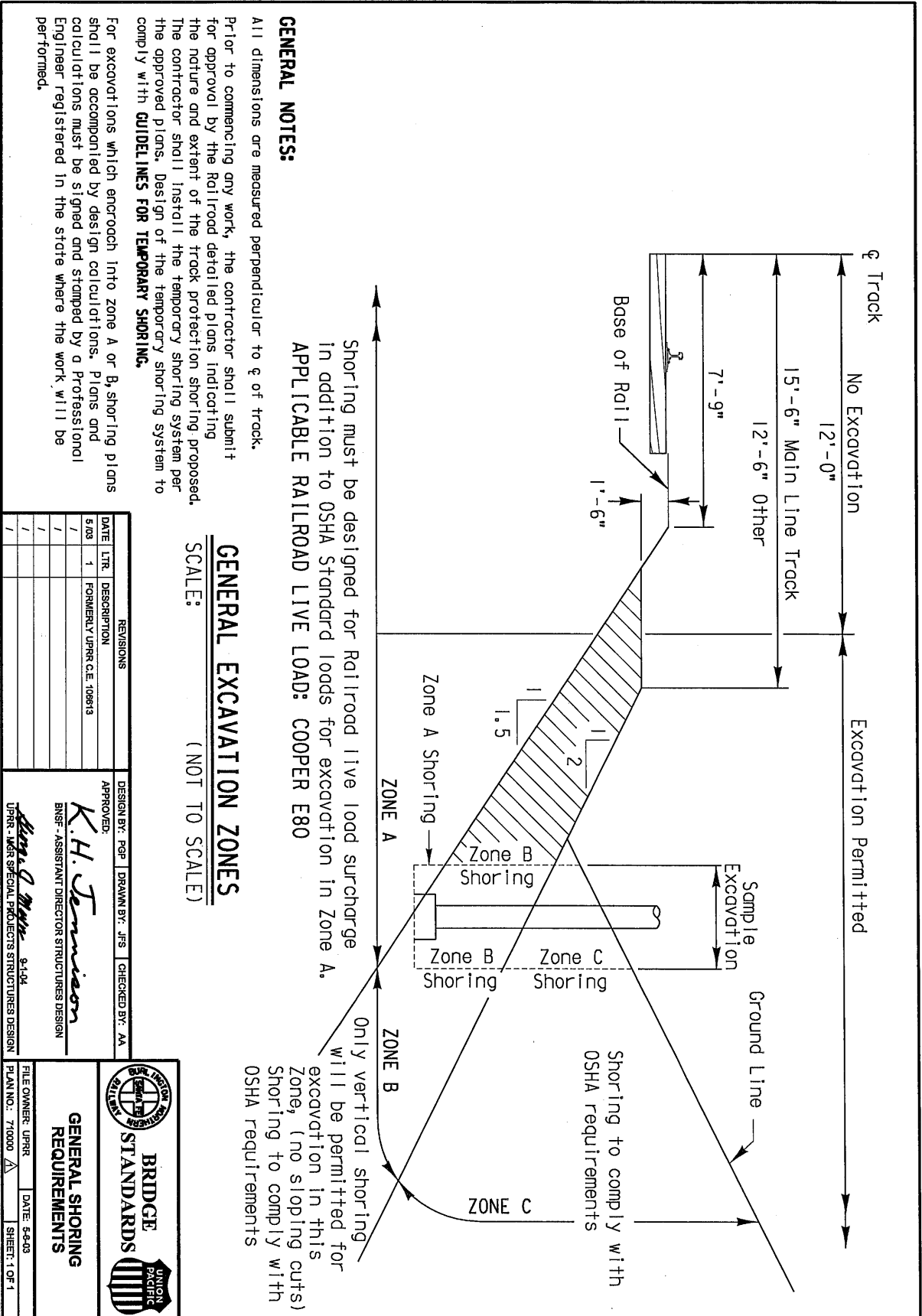

Figure 1

Montana Rail Link Shoring Specifications

1.01.07 For any bridge demolition and/or falsework above any tracks or any excavations located with any part of the excavations located within, whichever is greater, twenty-five (25) feet of the nearest track or intersecting a slope from the plane of the top of rail on a 2 horizontal to 1 vertical slope beginning at eleven (11) feet from centerline of the nearest track, both measured perpendicular to center line of track, furnish the Railway a pdf electronic file (with included working drawings to be legibly printable on 11"x17" paper) showing details of construction affecting Railway Property and tracks. Ensure the working drawings include the proposed method of installation and removal of falsework, shoring or cribbing, not included in the contract plans and ensure each of the sets of plans includes complete structural calculations of any demolition, falsework, shoring, or cribbing. For all excavation and shoring submittal plans, the current "BNSF-UPRR Guidelines for Temporary Shoring" (<http://www.bnsf.com/in-the-community/pdf/bnsf-up-shoring-guide.pdf>) must be used for determining design loading conditions to be used in shoring design, and all calculations and submittals must be in accordance with the current "BNSF-UPRR Guidelines for Temporary Shoring". For all demolition and false work plans, the current "BNSF Guidelines for Preparation of Bridge Demolition & Removal Plan Over the BNSF Railway" (<http://www.bnsf.com/in-the-community/pdf/bnsf-demolition-guideline.pdf>) Sections I, II, III, IV and Appendixes must be followed. Ensure all submittal drawings and calculations are sealed by a currently registered Professional Engineer licensed in the State of Montana. Ensure all calculations take into consideration railroad surcharge loading and are designed to meet American Railway Engineering and Maintenance-of-Way Association (previously known as American Railway Engineering Association)(AREMA) Coopers E-80 live loading standard. The Railway will notify the Contractor of Railway's comments, and Railway will advise the City's Engineer and Contractor at the time when the Railway has no objections to submittals. Contractor may not begin work covered under submittals provided in accordance with this section until Railway has provided, in writing, a statement of no objections. The Contractor will be required to use lifting devices, such as cranes and/or winches, to place or to remove any false work over Railway's tracks. The Contractor is in no way to be relieved of responsibility for results obtained by the implementation of said plans. **Railway has 30 calendar days to review each submittal and provide comments.**

Excerpted from MRL Exhibit C Contractor Requirements for MDT Project 9928